

Maintenance Maximus Eco 4500-6000-8000

1. Disconnect pump from the mains electrical supply.
2. Remove outer shell and clean in water.
3. Remove the 3 Screws
4. Remove impeller housing Inspect and clean if necessary.
5. Inspect site of impellor housing and o-ring. Clean if necessary.
6. Check impeller for any debris. Clean if necessary.
7. Check if impeller runs freely: if not, rotate several times until impeller is free to rotate.
8. There are no other consumer maintenance items in these pumps.
9. Reassembly is a straightforward reversal of the above procedure.

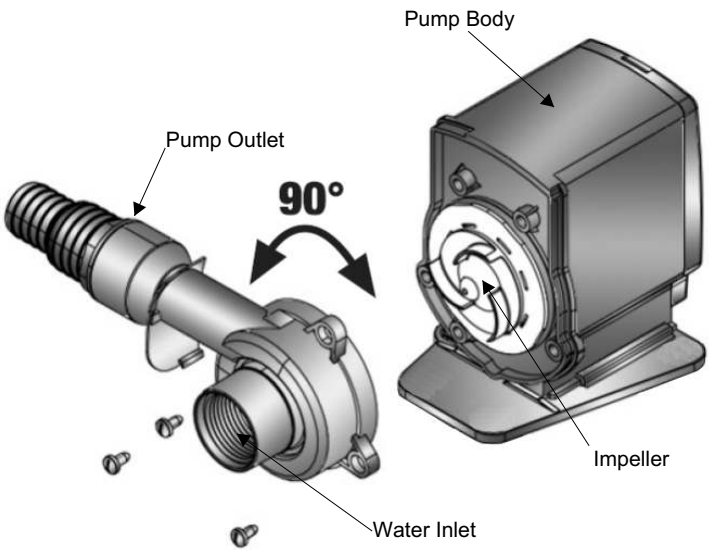

**INSTALLATION
AND
MAINTENANCE
INSTRUCTIONS**

WARRANTY

For 36 months (3 years) from the date of purchase OAL will repair or replace this pump, free of charge, if defective in material or workmanship. The ceramic bearings and shaft contained within this pump are guaranteed for the life of the pump. The maintenance schedule must be followed. This warranty will be invalid if the pump is not maintained in accordance with the instructions within this manual.- To claim please see below.

LIMITATION OF WARRANTY

OAL will not be liable for normal "wear and tear" items as indicated in this owners manual. No liability is assumed with regard to loss or damage of livestock or property irrespective of the cause thereof. This warranty does not affect your statutory rights. Failure caused by misuse is not covered by this warranty.

This warranty is invalid if the product fails as the result of accidental damage, improper installation, or failure to maintain as directed in this owners manual. Neglect, misuse, modification or use with any liquid other than fresh, clean water (above freezing point, but below +35C) will invalidate this warranty. The use of this pump below the rated depth (2 metres) will invalidate this warranty. Running this pump dry or without the pump body/base cover will invalidate this warranty.

HOW TO CLAIM

DO NOT return the pump to the retailer. Either contact us by telephone/email or send the pump, securely packed With your name and address. Enclose a brief note advising the nature of the fault. If repair is claimed under warranty, proof of purchase receipt MUST be returned with the pump.



OAL WATER GARDEN PRODUCTS LTD.
Oasis House, Deer Park Ind Est, Knowle Lane
Fair Oak, Eastleigh, Hants, SO50 7PZ
+44 (0) 23 8060 2602
Email: info@oasis-water-gardens.com www.oalwatergardens.com



**800, 1200, 1700, 2300, 3000, 4500,
6000 & 8000**

* Depending on model - Compared to previous Maximus Pump Models



Safety instructions for all Maximus Eco Models

Introduction

All pumps are intended for submersible use. To ensure optimum performance and safety from you Maximus Eco pump please comply with the following instructions.

ELECTRICAL CONNECTIONS



NEUTRAL = BLUE N
EARTH = GREEN & YELLOW
LIVE = BROWN L

The pump comes complete with 10 mtrs of 3 core cable, however, should any additional cable be required then the use of an approved waterproof cable connector is essential.

The power supply must be earthed and fused at 3amps.
Regularly inspect the cable for damage and deterioration
Always use a residual circuit device (RCD) for additional safety
For permanent installation to the mains supply, it is necessary to comply with the regulations of the Local Electricity Authority.
Consult a qualified electrician if in doubt about any aspects of wiring.

INSTALLATION

WARNING: Always unplug or disconnect the pump from the electrical supply before putting your hands (or any part of your body) in the water or whilst the pump is being installed, repaired, maintained or handled.

All pumps are intended for submersible use and MUST BE under water at all times for proper operation and cooling.

Never run a pump dry.

The pump should be installed on a firm base in the pond so that the fountain jet is just above the surface of the water.

If needed, the telescopic pipe can be adjusted in length (all models) and moved to find the vertical position (from model 1200).

WINTER MONTHS

During the winter months, when most decorative fountains are not required, the pump should either be removed from the pond and thoroughly dried or operated for a few minutes every week to ensure that the rotating parts remain free.

During frosty periods, operation of the pump with the fountain jet removed will assist in preventing the pond from freezing over.

LOW FLOW TO WATERFALL/FILTER OR LOW FOUNTAIN JET

- Check outer shell is clean.
- Check impeller cover is clean.
- Check waterfall connection is not blocked
- Check t-piece flow adjuster is not set too low.
- Check hose is not blocked or kinked.
- Check fountain jet is clean.
- Check pump flow adjuster is not set to minimum.

PUMP DOES NOT APPEAR TO BE WORKING AT ALL

Check the power supply is properly connected and working.

Check fuse.

Disconnect electrical supply. Remove pump and follow maintenance instructions.

MAXIMUS PUMPS FOUNTAIN JETS

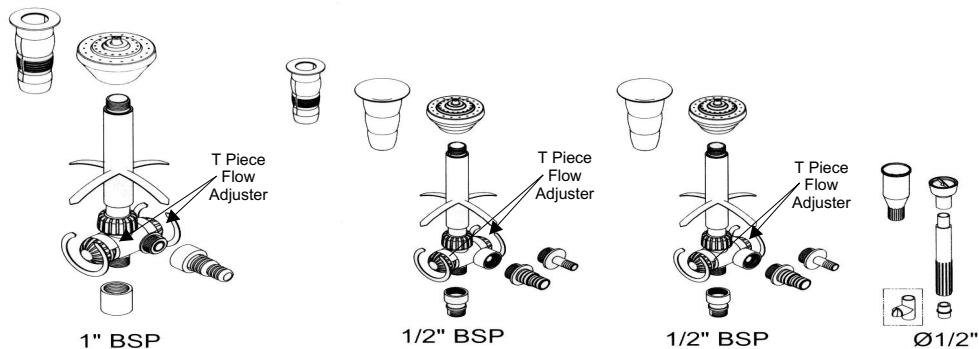

4500/6000/8000

1700/2300/3000

1200

800

Maintenance Maximus Eco 800/12000

1. Disconnect pump from the mains/electrical supply.
2. Remove outer shell and clean in water.
3. Remove impeller cover by rotating anti-clockwise. Inspect and clean if necessary.
4. Withdraw the magnet/impeller assembly: Inspect and clean it if necessary. Check there is no limescale built up on magnet: If the impeller is cracked - replace it.
5. Reassembly is a straight forward reversal of the above procedure.

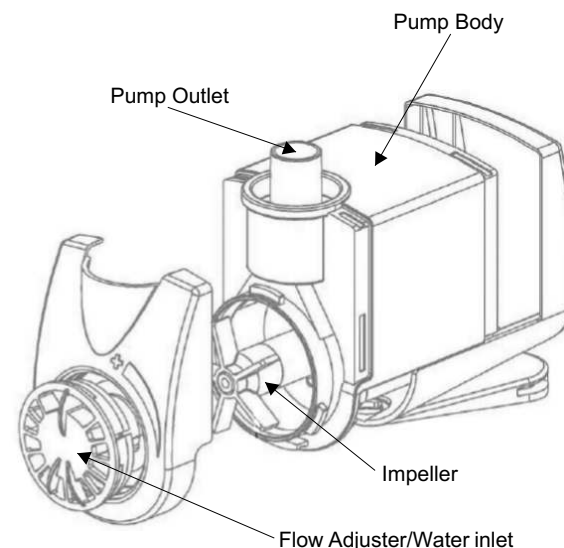

Maintenance Maximus Eco 1700/2300/3000

1. Disconnect pump from the mains/electrical supply.
2. Remove outer shell and clean in water.
3. Remove impeller cover by rotating anti-clockwise. Inspect and clean if necessary.
4. Withdraw the magnet/impeller assembly all together with ceramic shaft and rubber cups

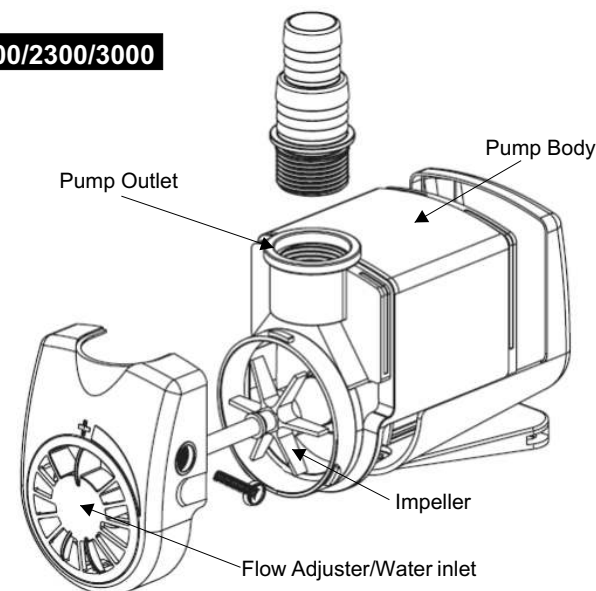

- CAUTION:** Ceramic shaft is hard but brittle. Inspect and clean magnet, impeller, shaft and rubber cups if necessary. Check there is no limescale built up on the magnet. Check for hairline cracks on magnet: if cracked, replace it.
5. Reassembly is a straight forward reversal of the above procedure.